

**Offspring Frequency with  
Assortative Mating and Autosomal Genes**

Female	X	Male	Frequency	Offspring		
				AA	Aa	A
AA		AA	$U + U^2$	$U + U^2$	—	—
AA		Aa	UV	$1/2 UV$	$1/2 UV$	—
AA		aa	UW	—	UW	—
Aa		AA	UV	$1/2UV$	$1/2UV$	—
Aa		Aa	$V^2$	$1/4V^2$	$1/2V^2$	$1/4V^2$
Aa		aa	VW	—	$1/2VW$	$1/2VW$
aa		AA	WU	—	WU	—
aa		Aa	WV	—	$1/2 WV$	$1/2 WV$
aa		aa	$W + W^2$			$W + W^2$
				$U'$	$V'$	$W'$

### Change in Allele Frequency With Assortative Mating

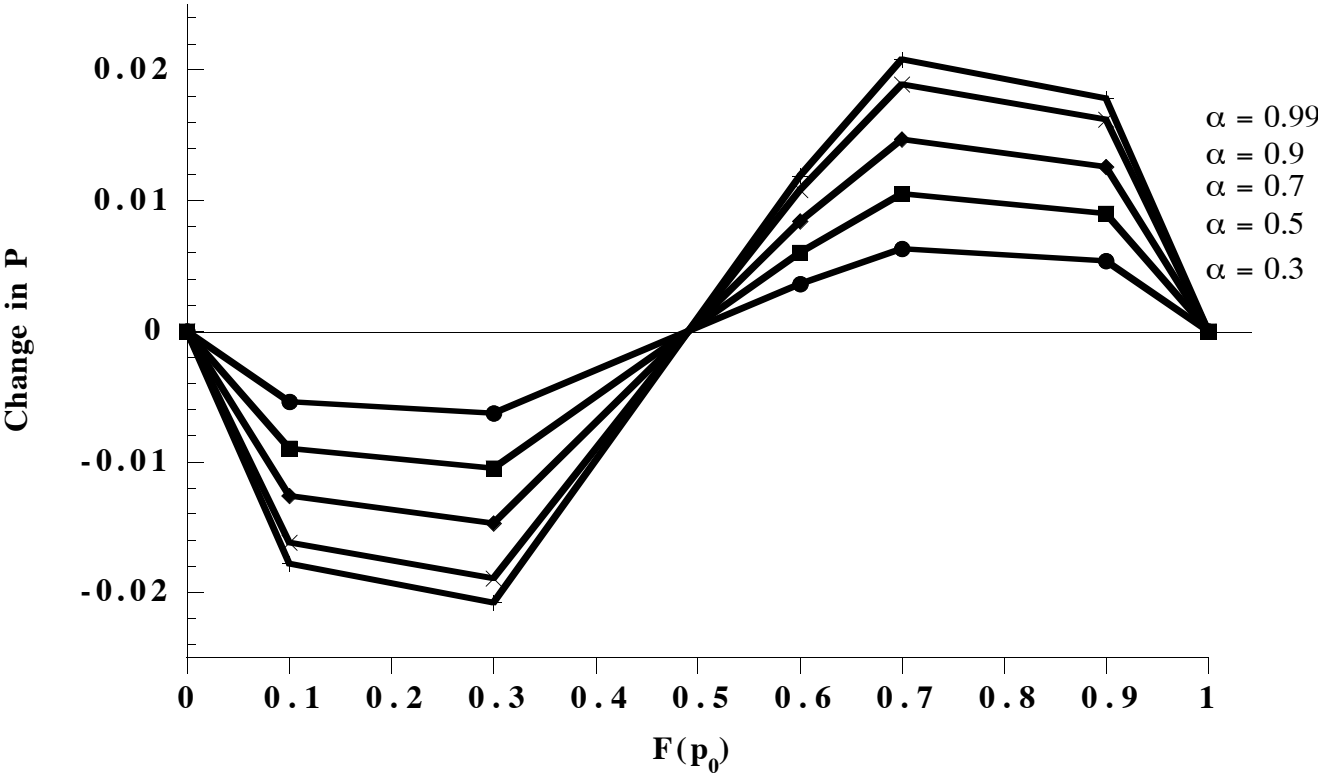

### Reduction in Allele Frequency With Irreversible Mutation

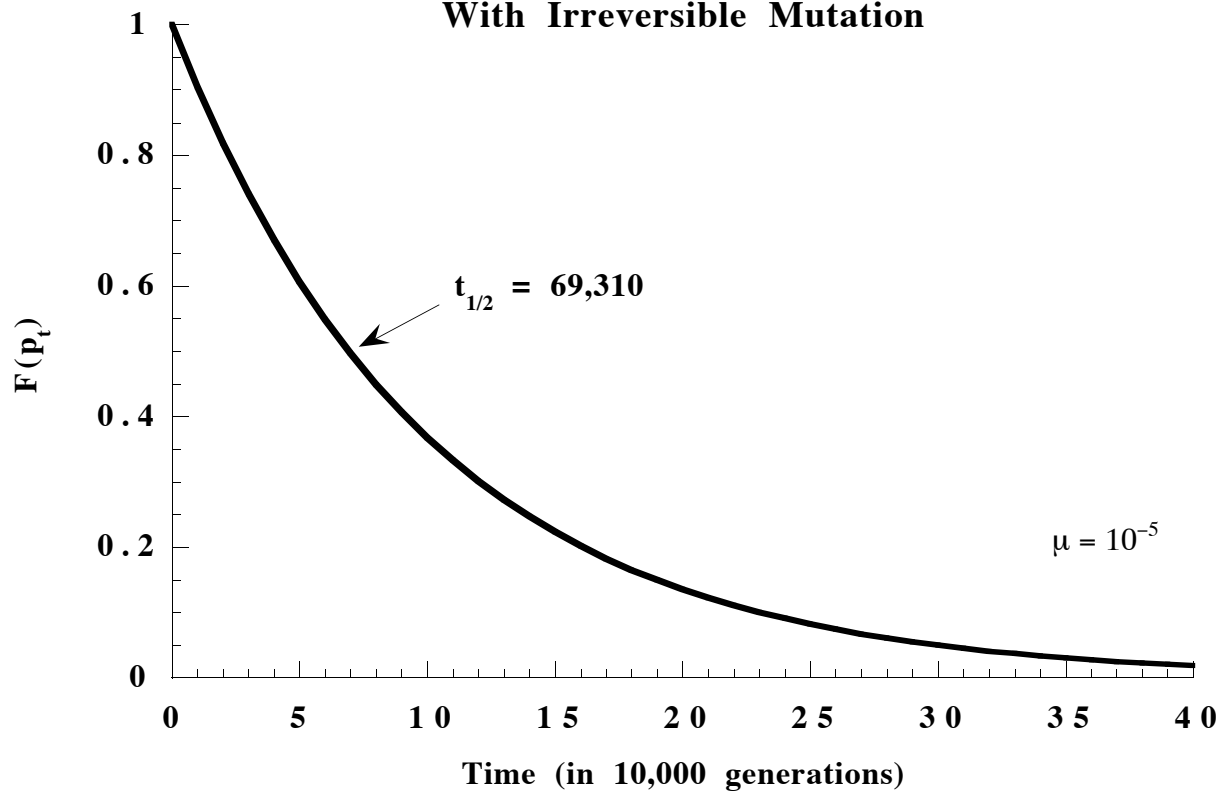

### Change in Allele Frequency With Reversible Mutation

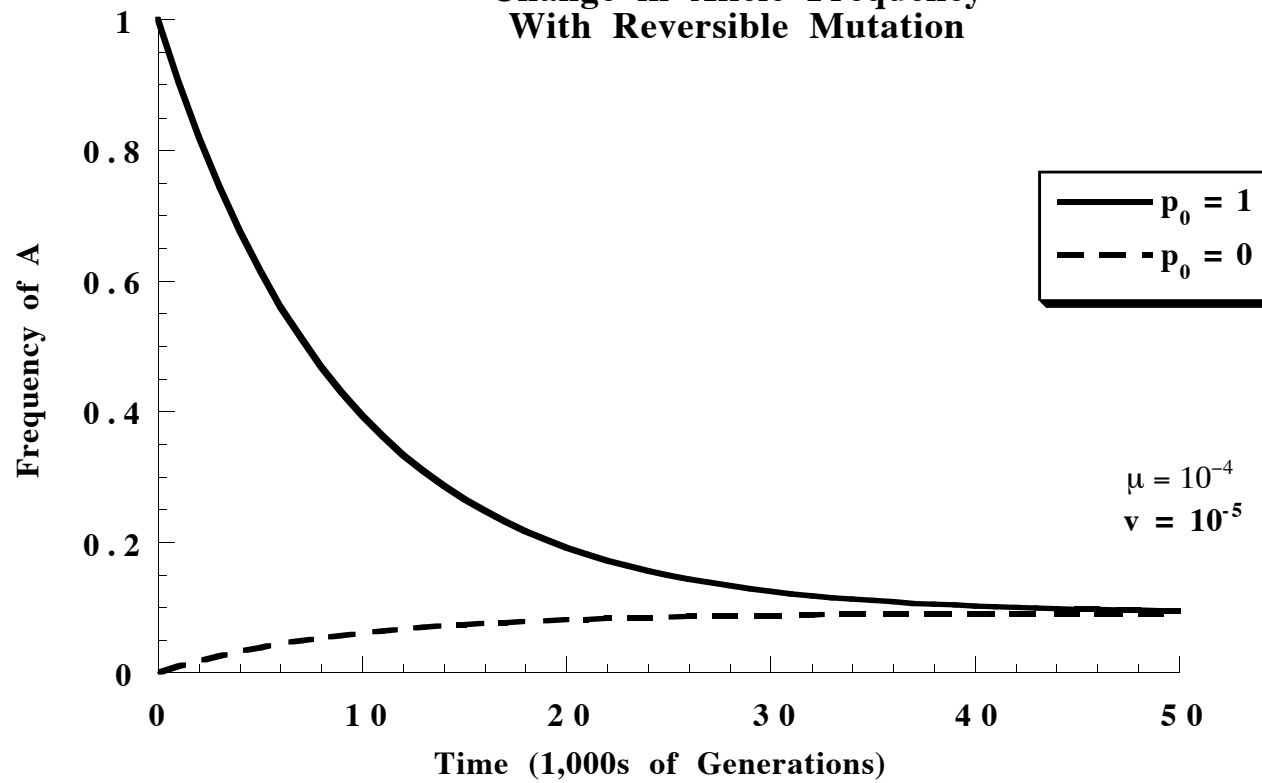

### Change in Equilibrium Genotype Frequencies with Population Size

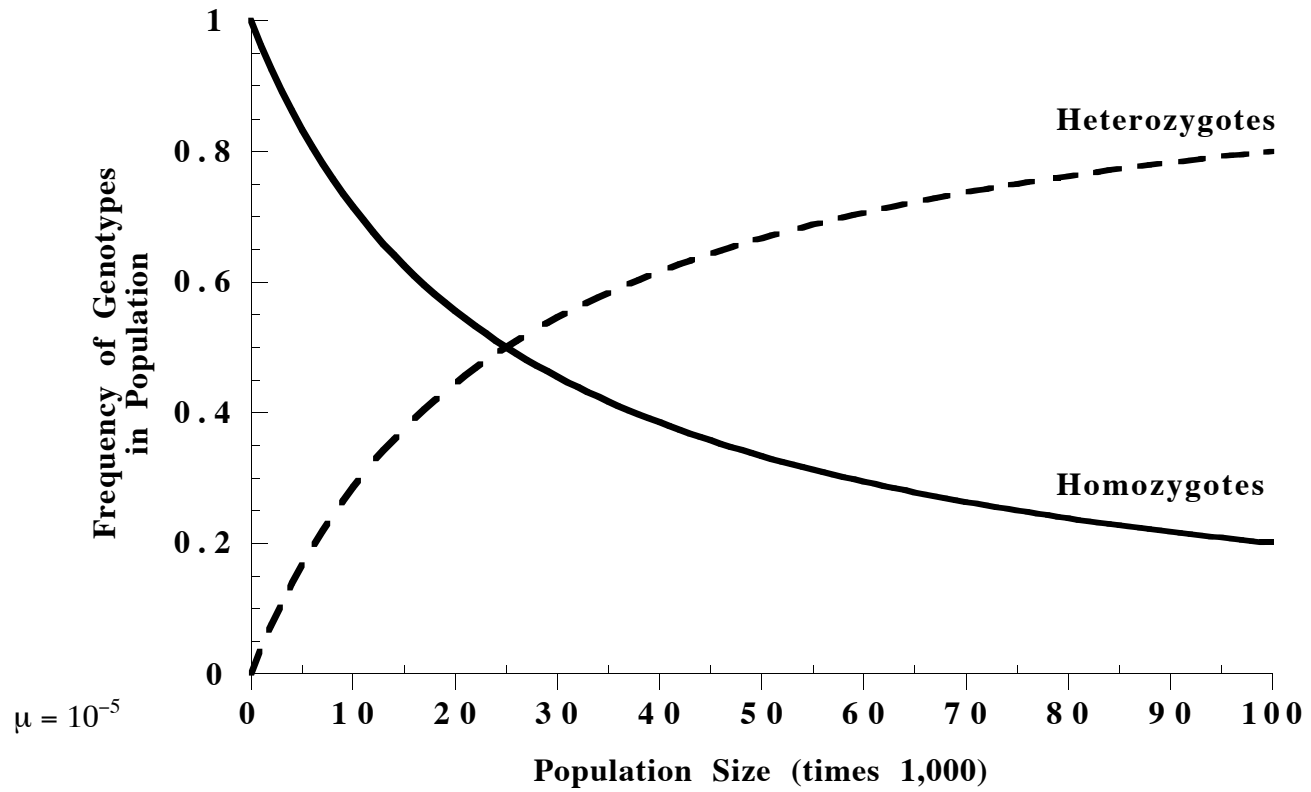

# Population Structure and Migration

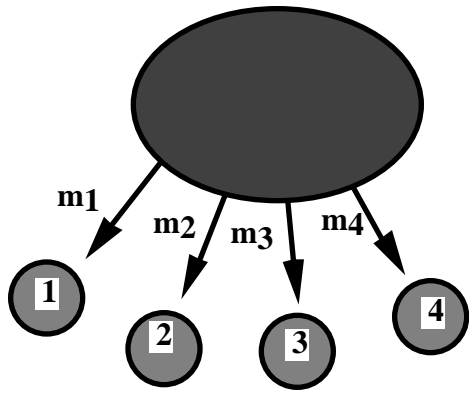

Island-Continent

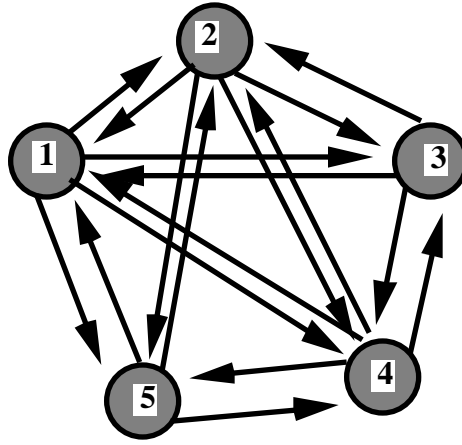

Island

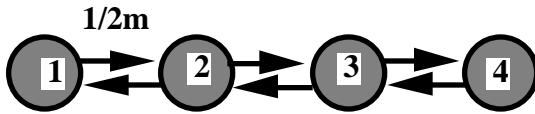

One-dimensional Stepping Stone

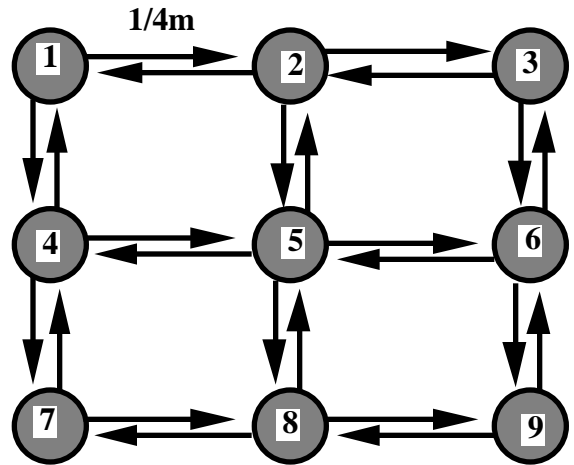

Two-dimensional Stepping Stone

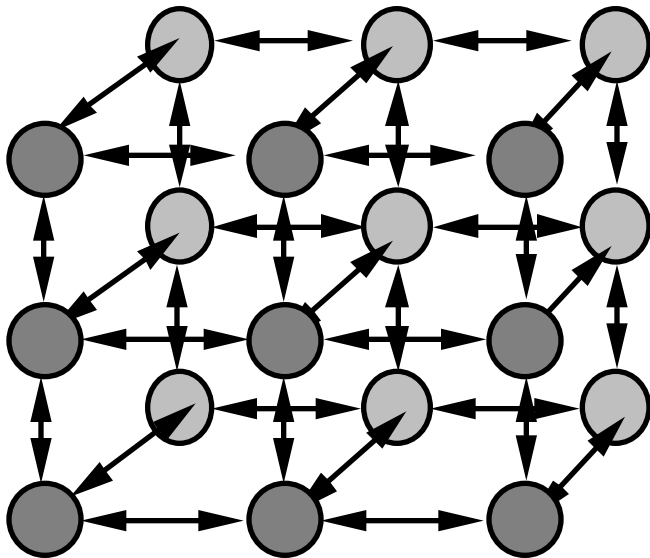

Three-dimensional Stepping Stone

Change in Allele Frequency  
With Island Model of Migration

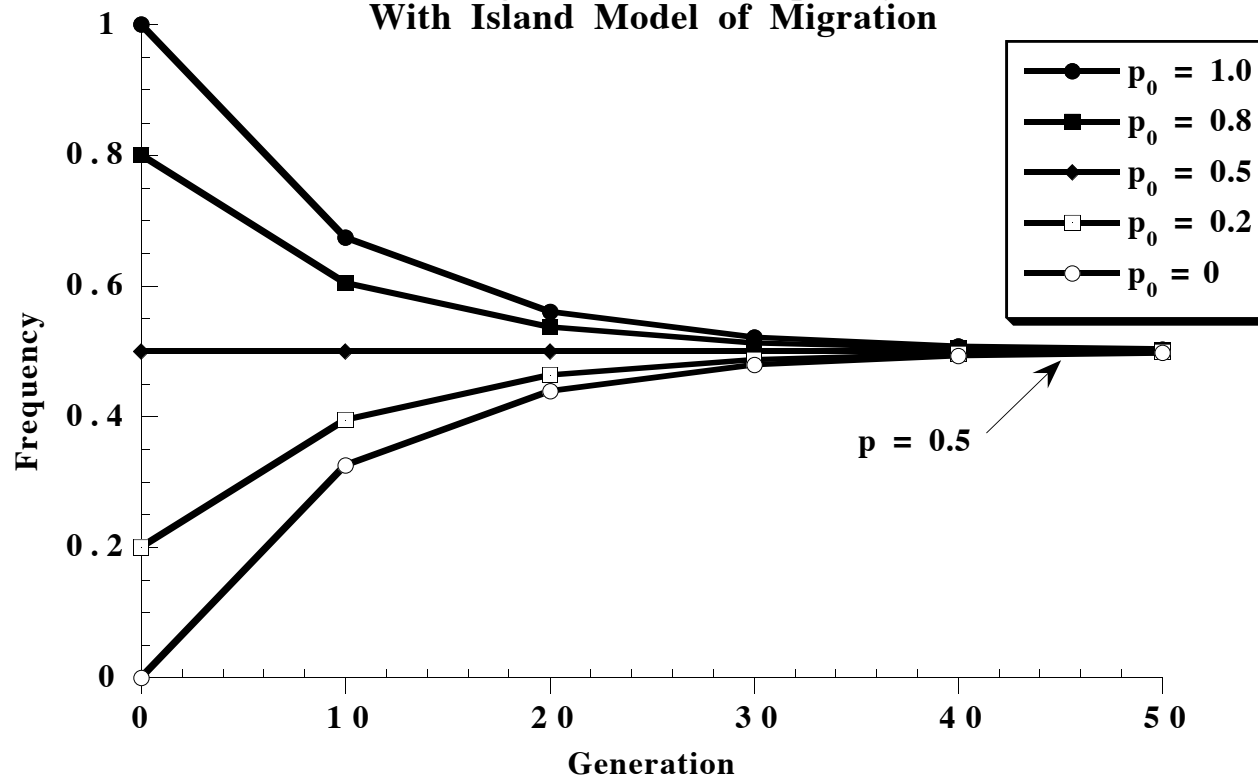

# Population Size, Recombination and Adaptive Variation

## Large Population Without Recombination

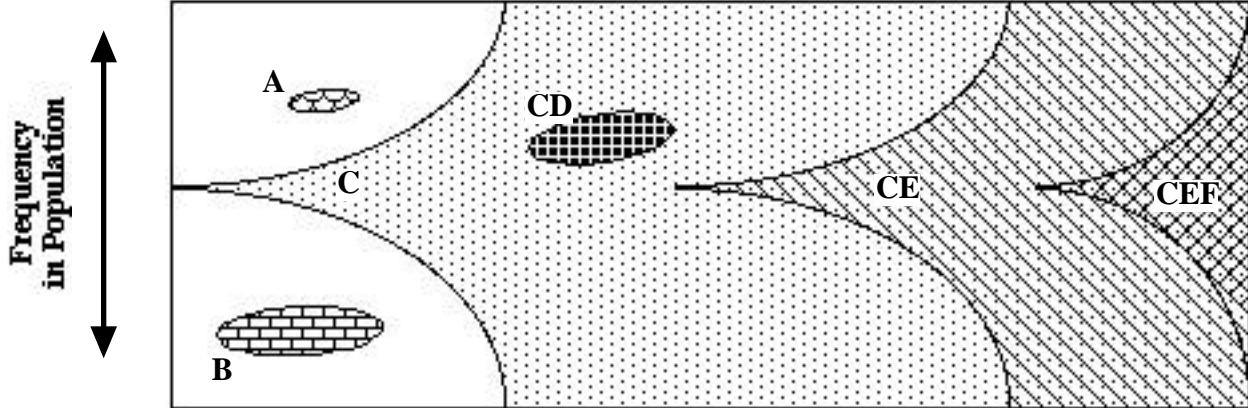

## Large Population With Recombination

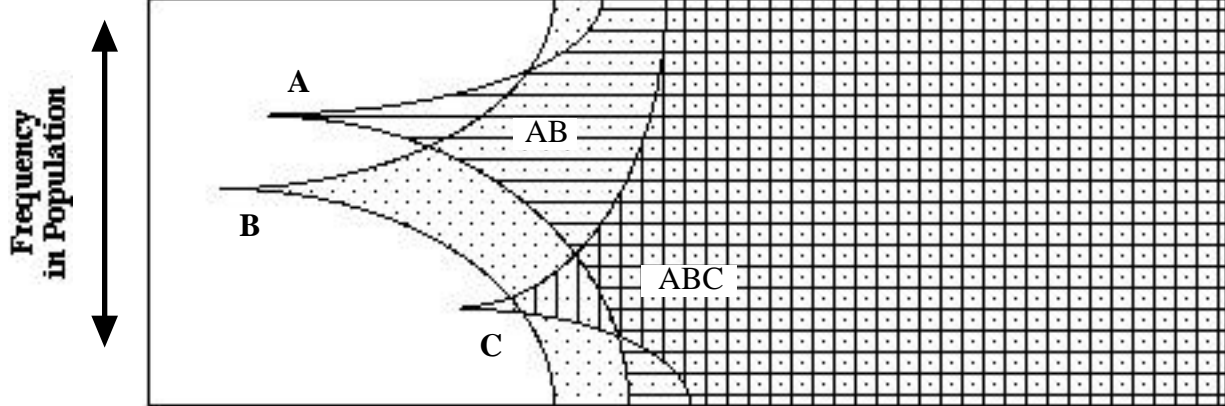

## Small Population Without Recombination

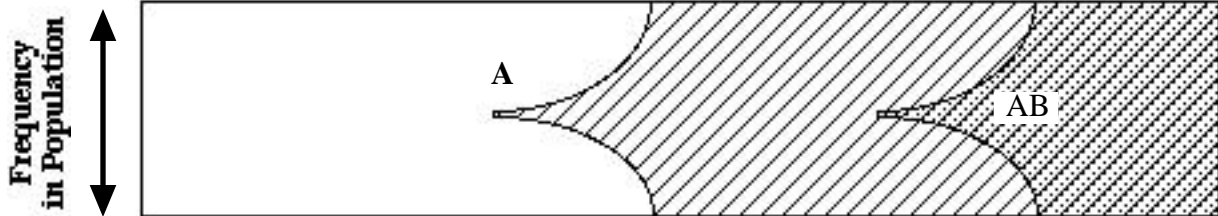

## Small Population With Recombination

